



Smart Solutions for Street Lights

Public lighting optimization is a major challenge in terms of attractiveness, safety and savings for public authorities, professionals or individuals. CandyLED responds to these needs by offering a solution to reduce costs and the environmental impact. It is the ideal solution for public lighting of high traffic roads, streets and residential lanes. This range benefits an excellent energy efficiency, requires little maintenance and offer 5 year warranty.

Applications

- Street Lights
- Highways
- Main roads and expressways
- Roads and Residential streets

Benefits

- Luminous efficacy: superior than 150 lumens/W
- Lens fitted: Road Optics
- Ingress Protection: IP66
- Mechanical Impact Protection: IK10
- Surge protection: 10Kv
- Lifespan: 100 000 H+
- Warranty : 5years
- Easy installation



Characteristics

| | |
|-------------------------------------|---|
| Nominal Power | 100-265V AC 50/60Hz |
| LED Technology | SMD |
| Power | 100W |
| Dimmability | No (Dimmable Driver 0/1 to 10 optionnal) |
| Surge Protection | 10Kv |
| Luminous efficiency | >150Lumens/W |
| Luminous Flux | 15 500 Lumens |
| Color Temperature | 3 000k - 4 000k - 6 500K Warm White - Neutral White - Cold White |
| Color Rendering Index | >=75 |
| Mechanical Impact Protection | IK10 |
| Ingress Protection | IP66 |
| Lifespan | 100 000H+ |
| Protection Class CEI | Class II |
| Operating Temperature | -10°C à +50°C |

Materials

| | |
|-------------------------|---------------------------|
| Body | Aluminium |
| Glasses | Thermally tempered glass |
| Sealing gasket | Anti-aging silicone seals |
| Screws and bolts | AISI 304 stainless steel |

Installation

Installation on vertical cross Range from Ø40mm to 65mm



Dimensions (mm)

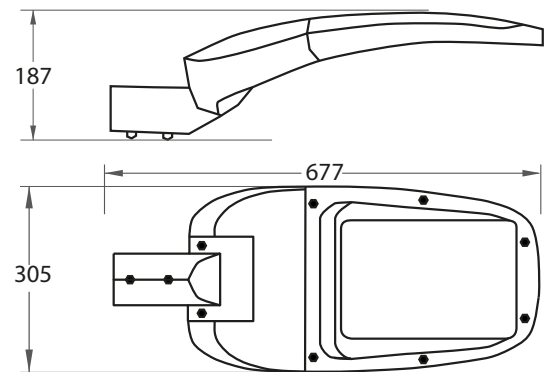

Length (mm) : 677 / Width (mm) : 305 / Height (mm) : 187

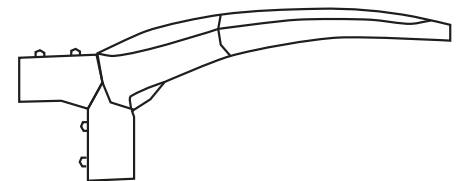

Angle d'inclinaison : de 0° à +90°